

Pre-Installation
Wiring & Functions
Vehicle Roof Installation

Standard Feet

- Permanent Mount
- Strap Kit Mount

Adjustable Feet

Flat Surface Installation
Narrow Surface Mount
Wide Surface Mount



PRE-INSTALLATION

To prevent damage to lightbar and vehicle, ensure that all equipment operates properly, and carefully plan where to mount and wire the lightbar and controlling equipment:

1. Verify that the lightbar and mounting hardware fit the vehicle.
2. Pre-configure desired lightbar functions.
3. Determine:
 - the location to mount the lightbar.
 - the location to route the lightbar's Power Cable.
 - the location to route the Function Cable, (eg. to siren, switch box, console).

WARNING: Take extreme care when routing wires around airbag areas to not interfere with it's proper operation.

4. Separate all electronic equipment wiring from two-way radio equipment wiring.
5. To avoid interference, keep two-way radio antennas a minimum of 50cm away from warning equipment.
6. After drilling holes, deburr and smooth sharp edges, and insert grommets to protect the wires from chafing.
7. When frame-ground the equipment, use the manufacturer-supplied ground locations in the vehicle.

WIRING & FUNCTIONS

Different applications require different functions. It is highly recommended to determine and configure the required functions prior to Installation; (refer to 'CONTROL CABLE' section).

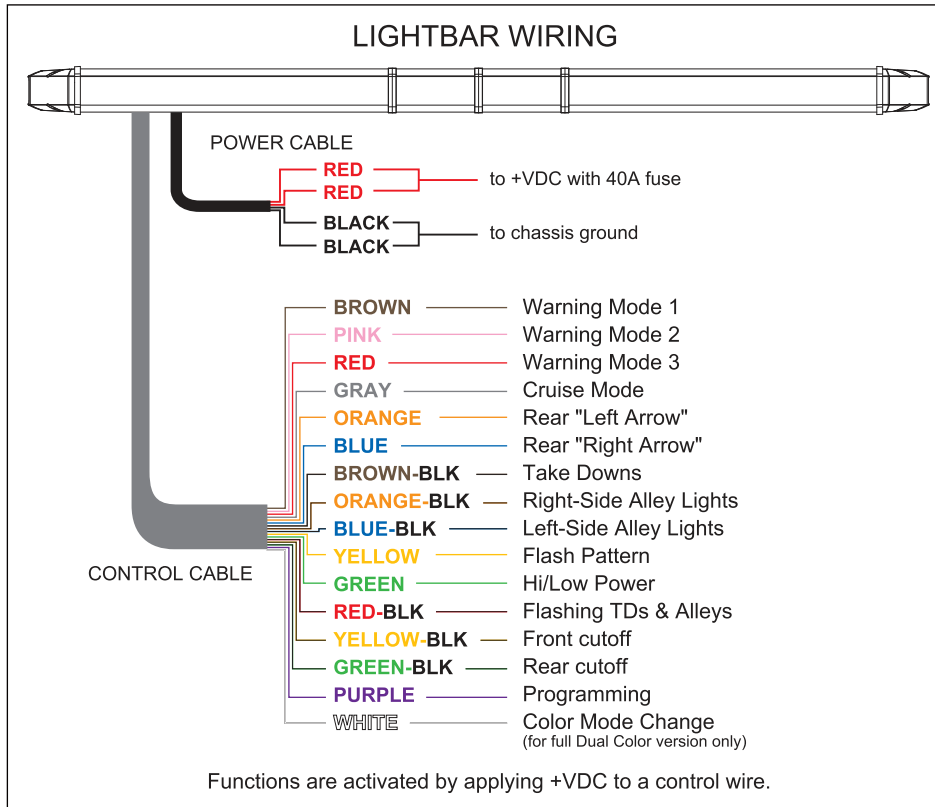

POWER CABLE

1. Route Power Cable to the vehicle firewall towards the battery.
2. Follow factory wiring harness through the firewall. It may be necessary to drill a hole in the firewall. Ensure that there are no components that could be damaged from the drilling.
3. Route the cable to the battery.
4. Splice the 2 **RED** wires to form a single wire.
5. Install a 40Amp fuse (user-supplied) on the end of **RED** wire, then connect to battery.
6. Splice the 2 **BLACK** wires to form a single wire.
7. Connect **BLACK** wire to the factory chassis ground adjacent to the battery.

NOTE: make sure that all wires of power cable are securely connected to power source.

TS_v.L1M1C1.2

CONTROL CABLE

1. Route Control Cable towards the dash area to a switch panel (user-supplied).
2. Connect the required wires to the switch panel.

WARNING MODE 1, MODE 2, MODE 3

In each Warning Mode, there is a list of built-in flash patterns to choose from.

To change flash patterns:

1. Activate the desired Mode by applying **+VDC** to **BROWN**, **PINK**, or **RED** wire.
 - **BROWN** wire for Warning Mode 1.
 - **PINK** wire for Warning Mode 2.
 - **RED** wire for Warning Mode 3.
2. While the Warning Mode is activated, tap **+VDC** to **YELLOW** wire:
 - Once for next pattern (refer to Flash Patterns charts).
 - Quickly 3 times for FP#0.

FP#	FLASH PATTERNS		
	Mode 1	Mode 2	Mode 3
0	Single Split (rear only)	Single Split	Random
1	Quad Split (rear only)	Quad Split	Quad Split
2	Ultra Split (rear only)	Ultra Split	Ultra Split
3	Single-Quad Split (rear only)	Single-Quad Split	Single-Quad Split
4	Side-by-Side Single (rear only)	Side-by-Side Single	Side-by-Side Single
5	Side-by-Side Quad (rear only)	Side-by-Side Ultra	Side-by-Side Ultra
6	Single Split (front only)	Outside-In Single	Outside-In Single
7	Quad Split (front only)	Outside-In Ultra	Outside-In Ultra
8	Ultra Split (front only)	Single All	Single All
9	Single-Quad (front only)	Quad All	Quad All
10	Side-by-Side Single (front only)	Ultra All	Ultra All
11	Side-by-Side Quad (front only)	Single-Quad All	Single-Quad All

NOTE: Flash Pattern #0 can be user customized by entering PROGRAM Mode, (refer to PROGRAMMING section). All other patterns are still available after customization is done. There is a reset function which restores original factory setting; refer to RESET section.

PROGRAMMING

FP#0 of each Warning Mode can be user customized.

To configure flash pattern:

1. Activate the desired Warning Mode by applying **+VDC** to: **BROWN** wire (Mode 1), **PINK** wire (Mode 2), or **RED** wire (Mode 3).
2. Enter PROGRAMMING mode by quickly tapping **+VDC** to **PURPLE** wire 3 times within 1 second.
3. Once in PROGRAMMING mode, all lighthoods will faintly blink once every second. The inner forward-facing pair of lighthoods will be activated.

NOTE: If the inner forward-facing heads are Take Downs, then tap **+VDC** to **PURPLE** wire once to scroll to the next pair of lighthoods.

4. Tap **+VDC** to **YELLOW** wire:
 - Once for next pattern (see Lighthouse Patterns).
 - Quickly 3 times within 1 second for FP#0.
5. If lightbar is equipped with full Dual Color function lighthouse color can be changed by momentarily applying **+VDC** to **WHITE** wire:
 - Color Mode1 = Color1 only
 - Color Mode2 = Color2 only
5. Scroll to the next pair of lighthoods by tapping **+VDC** to **PURPLE** wire.
6. Repeat steps 4 and 5 until all lighthoods are properly configured.
7. Exit PROGRAM mode by quickly tapping **+VDC** to **PURPLE** wire 3 times within 1 second.

FP#	Lighthouse Patterns
0	Steady
1	Single Slow (split)
2	Single Mid (split)
3	Single Fast (split)
4	Double (split)
5	Double (split)
6	Quint (split)
7	Ultra (split)
8	Single-Quad (split)
9	Single H/L (split)
10	Random
11	Off
12	Single Slow (all)
13	Single Mid (all)
14	Single Fast (all)
15	Double (all)
16	Double (all)
17	Quint (all)
18	Ultra (all)
19	Single-Quad (all)
20	Single H/L (all)

RESETTING

To restore factory setting:

1. With no wires activated, enter RESET mode by tapping **+VDC** to **PURPLE** wire for more than 1 second.
2. Once in RESETTING mode, the lightbar will display:
single flash = Mode 1 or double flash = Mode 2 or triple flash = Mode 3
3. Select Mode to reset by tapping **+VDC** to **PURPLE** wire once to change Modes.
4. Apply **+VDC** to **PURPLE** wire for 2~4 seconds to restore factory setting.
5. Exit RESETTING mode by tapping **+VDC** to **PURPLE** wire for 5 seconds or more.

TS_v.L1M1C1.2

FLASHING TDs & ALLEYS

Activate Flashing TDs & Alleys by applying **+VDC** to **RED-BLK** wire. To scroll to a different configuration, tap **+VDC** to **YELLOW** wire:

- TDs and Alleys flashing
- Alleys only flashing
- TDs **+VDC** to only flashing

NOTE: Flashing TDs & Alleys have priority over the steady burn functions.

CRUISE MODE

Activate Cruise mode by applying **+VDC** to **GRAY** wire. All corner lighthoods will be activated in low power steady burn. To activate more lighthoods tap **+VDC** to **PURPLE** wire while in CRUISE mode; the lighthoods immediately next to the corner lighthoods will be activated.

TRAFFIC ARROWS

During Mode 1, Mode 2, or Cruise mode, activate Traffic Arrow functions by applying **+VDC** to:

- **ORANGE** wire for Left Arrow.
- **BLUE** wire for Right Arrow.
- **ORANGE** & **BLUE** wires for Center Out.

To configure the Traffic Arrow flash patterns, tap **+VDC** to **YELLOW** wire:

- Once for next pattern (refer to Traffic Arrow Patterns chart).
- Quickly 3 times within 1 second for reset to FP#0.

FP#	Traffic Arrow Patterns
0	Sweep Single
1	Sweep Double
2	Sweep Triple
3	Sweep Single End-Double
4	Solid
5	Solid End-Double
6	Solid Chaser
7	Solid Fade
8	Blink Double
9	Blink Triple
10	Blink Solid

NOTE: If the bar is equipped with Dual Color Traffic Arrow option, the rear lighthoods will automatically switch to Color2 when Traffic Arrow function is activated, and will automatically switch to Color1 when Traffic Arrow function is deactivated.

OTHERS

To activate other functions, apply **+VDC** to:

- **BROWN-BLK** wire for Take Down Lights
- **ORANGE- BLK** wire for Right-Side Alley Light
- **BLUE-BLK** wire for Left-Side Alley Light
- **YELLOW- BLK** wire for Front cutoff
- **GREEN- BLK** wire for Rear cutoff
- **GREEN** wire for Low Power
- **WHITE** wire for Color Mode Change (for full Dual Color version only)
(Color1 changes to Color2 during Warning Modes)

VEHICLE ROOF INSTALLATION

STANDARD FEET

Install Mounting Feet on the Lightbar

1. Turn the lightbar upside down.
2. Place mounting feet over the carriage bolts.
3. Attach a lockwasher and a nut on each of the carriage bolts, but do not completely tighten the bolts. Leave them loose enough to reposition the mounting foot.

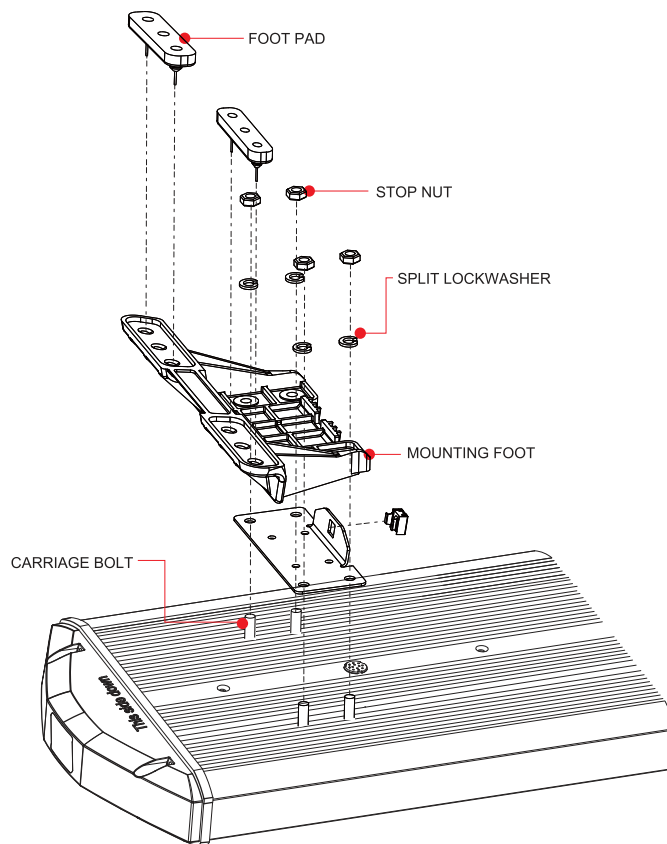

Upside down view of lightbar with mounting foot

PERMANENT MOUNT

Installation includes centering the lightbar on the vehicle's roof, leveling the lightbar, and scribing and drilling holes for mounting the lightbar permanently to the roof.

1. Place lightbar on the vehicle roof at the desired location. The lightbar is usually centered on the door center post (B-pillar).
2. Adjust both mounting feet in or out as necessary until the foot pads rest near the edge of the roof or gutter where the roof is the most rigid. Make sure the lightbar and the mounting feet are centered left to right on the vehicle.
3. Level the lightbar by shifting the lightbar slightly forward or back.
4. Using the mounting feet as a template, mark two drilling holes on each end of the vehicle roof.
5. Carefully remove the lightbar and turn it upside down, and ensure that the mounting feet do not shift place.
6. Tighten the nuts that secure the mounting feet to the lightbar.
7. Drill four holes at the previously marked drilling positions.

WARNING: DO NOT DRILL THROUGH the roof support structure that spans the distance between the driver's and passenger's side. Drilling through this will weaken the roof of the vehicle.

NOTE: Before drilling holes, ensure that the holes will go through sheet metal and not the upholstery. And ensure that no damages are caused to the vehicle components.

8. Place lightbar on the vehicle roof and align the mounting holes with the mounting feet. Secure mounting feet to vehicle roof with carriage bolts.

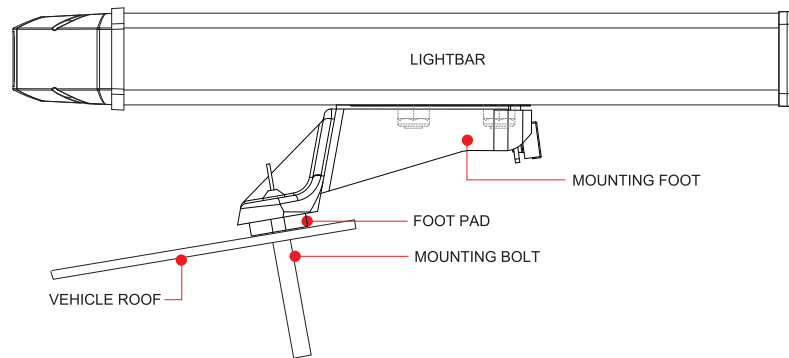

Front view of lightbar with Permanent mount

NOTE: After installation, frequently inspect the lightbar and mounting feet to ensure that all fasteners and brackets are tight.

STRAP KIT MOUNT

The Strap Kit is designed for specific make and mode of vehicle. Before installation, ensure that the correct strap kit is used.

1. Place the lightbar on the vehicle roof at the desired location. Usually, the lightbar should be centered on the center door post (B-pillar).

NOTE: Water may leak into the vehicle interior if the straps are improperly positioned. Ensure that the straps are positioned above or near the center door post (B-pillar).

2. Determine where the straps will attach to the vehicle.

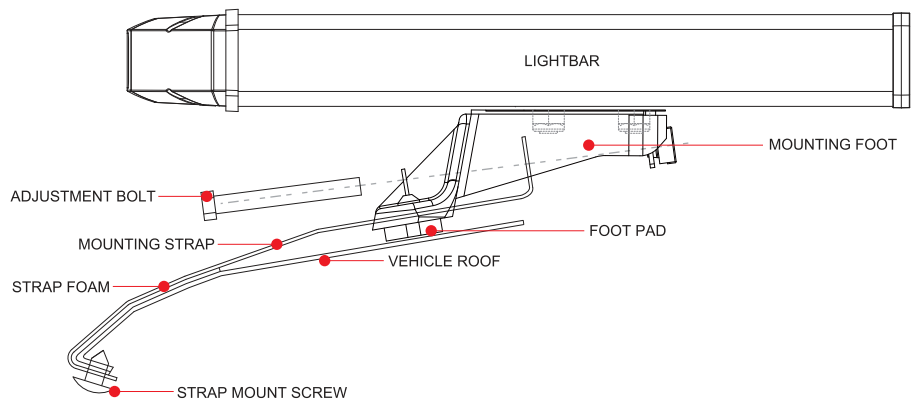

Front view of lightbar with Strap Kit mount

3. Place the straps in position on the roof sheet metal as shown in diagram.
4. Use the straps as a template and mark the drilling hole locations.
5. Drill holes according to the marked locations.
6. Apply a silicone sealant (user-supplier) around the holes before attaching the straps.
7. Secure the straps with the sheet metal screws.

NOTE: After installation, frequently inspect the lightbar and mounting feet to ensure that all fasteners and brackets are tight.

8. Place the lightbar on the vehicle roof, and align strap bolt holes with lightbar mounting feet bolt holes.
9. Insert adjustment bolt through strap bolt hole all the way to mounting feet bolt hole.
10. Tighten bolts.

ADJUSTABLE FEET

Install Mounting Feet on the Lightbar

1. Turn the lightbar upside down.
2. Place mounting feet over the carriage bolts.
3. Attach a lockwasher and a nut on each of the carriage bolts, but do not completely tighten the bolts. Leave them loose enough to reposition the mounting foot.

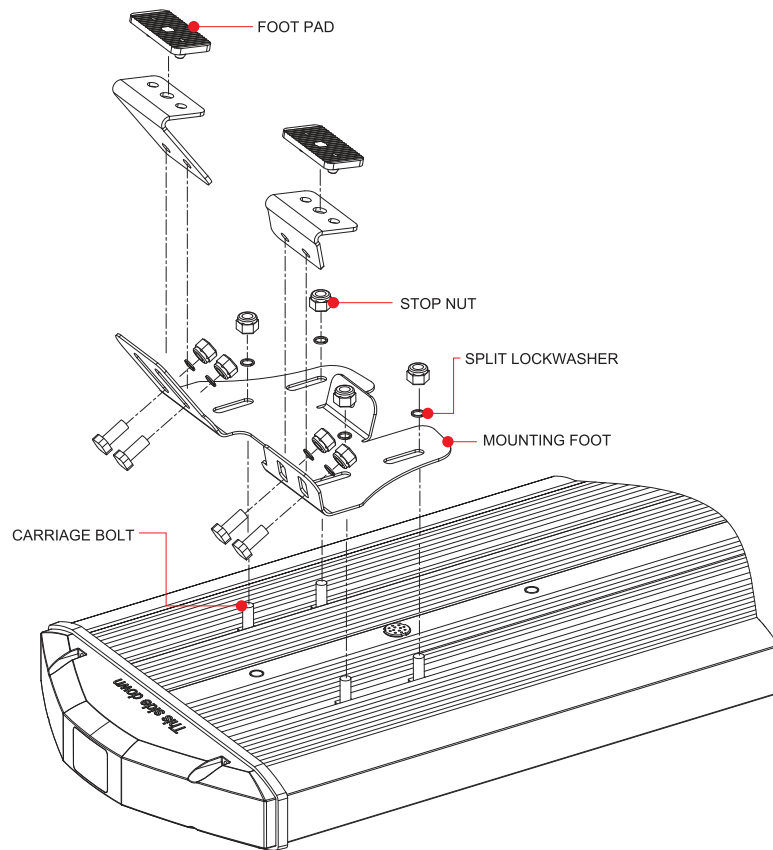

Upside down view of lightbar with mounting foot

FLAT SURFACE INSTALLATION

NARROW SURFACE MOUNT

1. Turn the lightbar upside down.
2. Place mounting feet over the carriage bolts.
3. Attach a lockwasher and a nut on each of the carriage bolts, but do not completely tighten the bolts. Leave them loose enough to reposition the mounting foot.

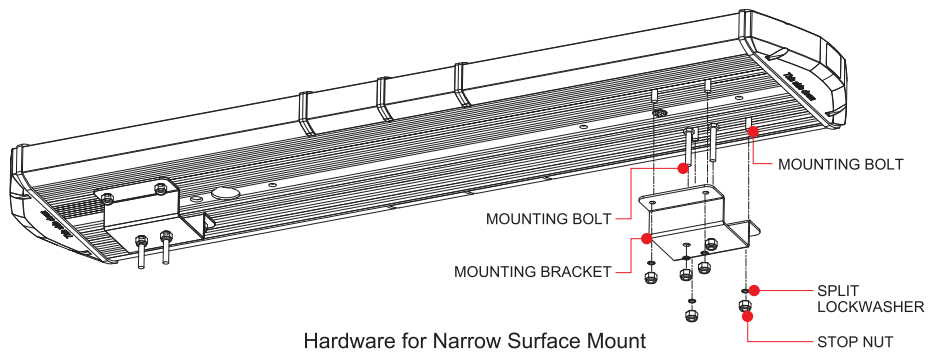

4. Place lightbar on the mounting surface at the desired location.
5. Adjust both mounting foot assemblies in or out as necessary. If possible, try to keep mounting feet near the ends of the lightbar.
6. Using the mounting feet as a template, mark two drilling holes on each end of the mounting surface.
7. Carefully remove the lightbar and turn it upside down, and ensure that the mounting feet do not shift place.
8. Tighten the nuts that secure the mounting feet to the lightbar.

NOTE: Before drilling holes in ANY part of the vehicle, be sure that both sides of the mounting surface are clear of parts that could be damaged, such as brake lines, fuel lines, electrical wiring, or other vital parts.

9. Drill four holes at the previously marked drilling positions.
10. Place lightbar on the mounting surface and align mounting holes with the mounting feet.
11. Secure mounting feet to mounting surface with carriage bolts.

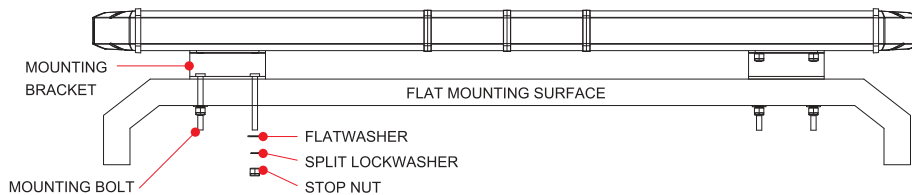

TS_v.L1M1C1.2

WIDE SURFACE MOUNT

1. Turn the lightbar upside down.
2. Place mounting feet over the carriage bolts.
3. Attach a lockwasher and a nut on each of the carriage bolts, but do not completely tighten the bolts. Leave them loose enough to reposition the mounting foot.

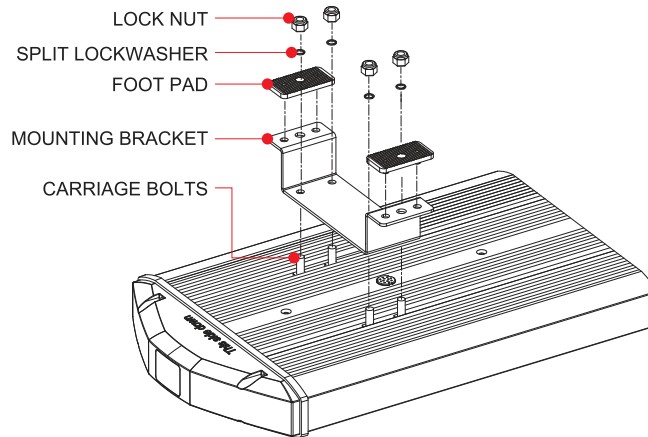

Upside down view of lightbar with mounting foot

4. Place lightbar on the mounting surface at the desired location.
 5. Adjust both mounting foot assemblies in or out as necessary. If possible, try to keep mounting feet near the ends of the lightbar.
 6. Using the mounting feet as a template, mark two drilling holes on each end of the mounting surface.
 7. Carefully remove the lightbar and turn it upside down, and ensure that the mounting feet do not shift place.
 8. Tighten the nuts that secure the mounting feet to the lightbar.
- NOTE:** Before drilling holes in ANY part of the vehicle, be sure that both sides of the mounting surface are clear of parts that could be damaged, such as brake lines, fuel lines, electrical wiring, or other vital parts.
9. Drill four holes at the previously marked drilling positions.
 10. Place lightbar on the mounting surface and align the mounting holes with the mounting feet.
 11. Secure mounting feet to mounting surface with carriage bolts.

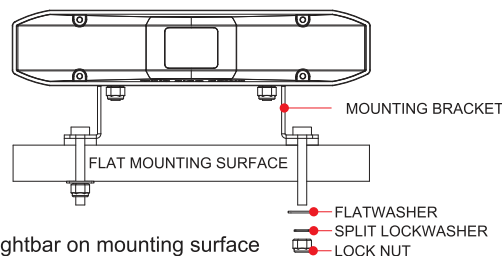

Side view of lightbar on mounting surface

TS_v.L1M1C1.2