

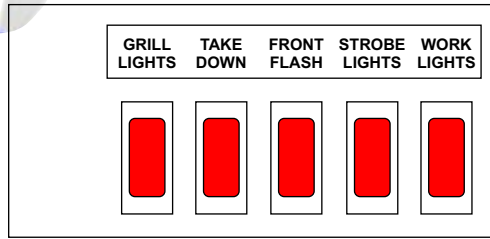

# BROOKING INDUSTRIES, INC.

10132 NW 53rd St.  
Sunrise, FL 33351

P 888-439-1925 or 954-572-0510  
F 877-363-7301 or 954-578-6007



## BR-950 5-Function Panel

Thank you for purchasing this Brooking Industries product. With proper installation and care, this unit will provide years of trouble-free service.

## BR-950 5-Function Panel

### Mounting:

This switching system comes with a swinging bracket which enables it to be mounted in more than one position. Positioning the bracket below the unit permits it to be mounted on a horizontal surface while positioning the bracket above the unit allows mounting to the underside of the dash. After determining where the unit will be located, use the mounting bracket as a guide to drill approximate size mounting holes. Where the unit is to be mounted will determine the type of hardware needed.

### Wiring:

Before making any electrical connections, determine the polarity of the vehicle's electrical system ground. Most vehicles require the RED (+) positive wire (14 gauge) be connected to the power source and the BLACK (-) negative wire (18 gauge) to be connected as the ground wire. The instructions below are for this type of installation. After making all the connections, verify that there are no short circuits to ground prior to connecting the positive (+) RED wire. The BLACK ground wire should be connected to the vehicle chassis as close to the unit as possible.

Connect the appropriate warning light accessory to the color coded wire which corresponds to the switch you want to use to control the accessory. Each switch is independently fused for your safety with a 20-amp fuse.

### Precautions:

Read and understand these instructions prior to installing or operating this equipment. Do not connect this system to the positive terminal of the battery until installation is Complete and you have verified there are no short circuits to the ground.

View - Inside Back Bottom

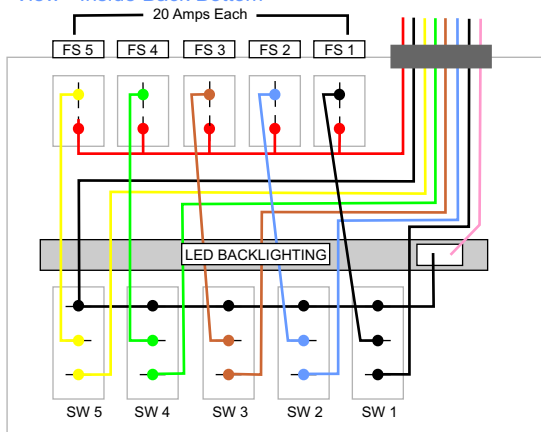

View - Front Top

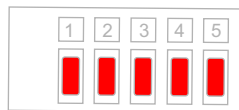

View - Inside Front Bottom

View - Front Bottom

Wire	AWG	Color	Item	Function
1	20	White	Switch 1	
2	20	Blue	Switch 2	
3	20	Brown	Switch 3	
4	20	Green	Switch 4	
5	20	Yellow	Switch 5	
B	18	Pink	Back Lt	Back Lt
	18	Black	Ground	Ground
H	14	Red	Power	Power

Function column intentionally left blank. Please fill in appropriate functions and store in glove box for future reference / tech support.

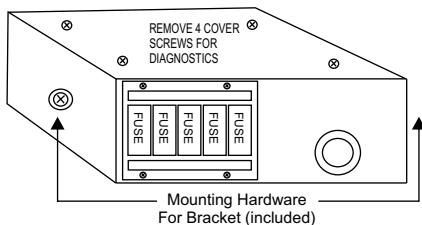

- ▶ LED Backlighting for Legends / Titles
- ▶ 5 Red Lighted Rocker Switches Rated @ 15 Amps Each Fused @ 20 Amps Each

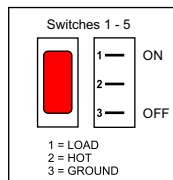

Scrape away any paint from the selected bolt hole and use a star washer and ring terminal to ensure a good, secure electrical connection to the chassis. The chassis ground must not be an insulated point.

**Note:** When drilling into any vehicle structure, ensure that both sides of the surface are clear of anything that can be damaged.

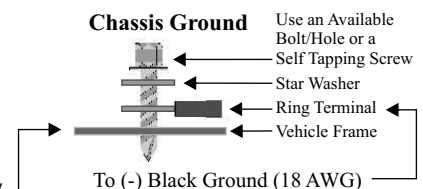

**A loose chassis ground connection WILL cause intermittent operation!**