

# BROOKING INDUSTRIES, INC.

10132 NW 53rd St.  
Sunrise, FL 33351

P 888-439-1925 or 954-572-0510  
F 877-363-7301 or 954-578-6007



## BR-991 12 Amp Digital Switch Panel

Thank you for purchasing this Brooking Industries product. With proper installation and care, this unit will provide years of trouble-free service.

### Function Table

Wire	AWG	Color	Function	Accessory
1	16	Grn/Yel	Switch 1	
2	16	Grn/Yel	Switch 2	
3	16	Grn/Yel	Switch 3	
4	16	Grn/Yel	Switch 4	
5	16	Grn/Yel	Switch 5	
6	16	Grn/Yel	Switch 6	
J5	18	Black	Ground	Ground
J5	18	White	Ignition	Ignition
	14	Red	Power	Power

Function column intentionally left blank. Please fill in appropriate functions and store in glove box for future reference / tech support.

## BR-991 Wiring Instructions

## Operation Notes

1. Plug in the 14 Gauge Red-Power wire (to battery)
2. Plug in the 2-position wire harness to J5 connector.
  - A. White - Hot Wire (ignition)
  - B. Black - Ground Wire
3. Attach the red wire to any power source, preferably the fuse box
4. Attach the black wire to a clean, unpainted grounding point
5. The three(3) green/yellow cables control the switch box functions.
6. To make installation easier, all connectors are plug/input specific.

1. If a switch has been associated with the Master switch, it can always be operated normally by pushing once (1) to turn ON and a second (2nd) time to turn OFF.
2. If a switch has been associated with and turned on via the Master switch it can be turned OFF by pushing it one (1) time.
3. If no buttons are pressed for one (1) minute while in programming mode, the unit will save the current settings and exit programming mode automatically.

Scrape away any paint from the selected bolt hole and use a star washer and ring terminal to ensure a good, secure electrical connection to the chassis. The chassis ground must not be an insulated point.

**Note:** When drilling into any vehicle structure, ensure that both sides of the surface are clear of anything that can be damaged.

### Chassis Ground

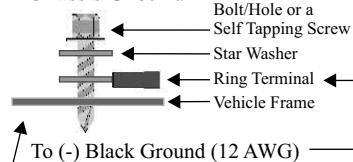

**A loose chassis ground connection WILL cause intermittent operation!**

### Panel Back Inside View

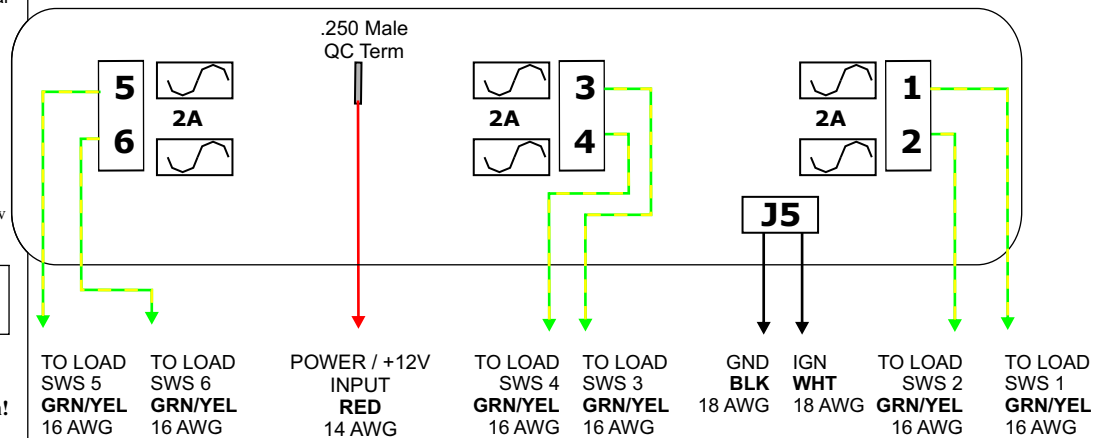

**Warning:** In standard format, each switch is ONLY rated for a maximum 10 Amp load per switch! Should your amp draw requirements exceed 10 Amps per switch, call 888-439-1925 to order our optional in-line 40 Amp relay kit, part number **BR-9RK**. These kits are available for \$12.95 each and will increase the maximum amp load capacity of one switch/lead to 40 Amps..

Switches flash to indicate they are associated to the Master Switch Program Mode.

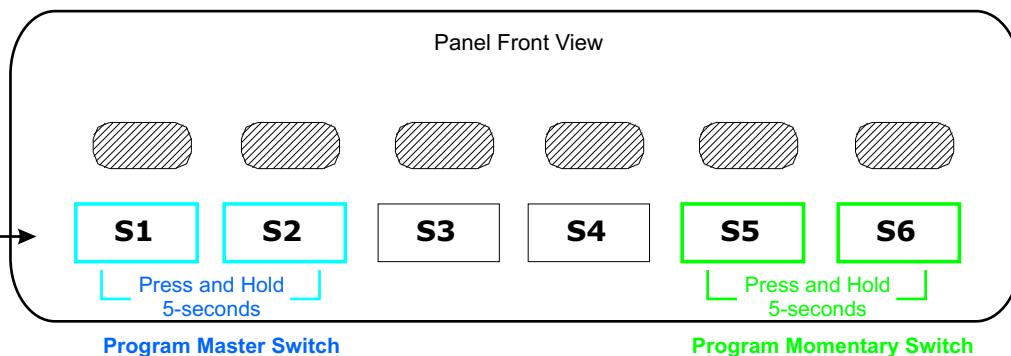

## Master Switch Programming Mode

- ▶ Switches 2 - 6 (5 switches total) can be associated with the Master Switch

### To Enter Master Switch Program Mode:

1. Press and hold switches 1 and 2 for 5-seconds (**S1 & S2** pictured above).  
All switch back light LEDs will blink ON and OFF twice  
This indicates that panel is in Master Switch Program Mode.
2. Press each switch that you want to associate with the Master Switch one (1) time. (**S2-S6** above)  
All switches will flash when associated with the Master Switch
3. Press switch a second (2nd) time to dis-associate it with the Master Switch  
Switch will stop flashing
4. To exit Momentary Switch Program Mode, press Switch 1 a second (2nd) time  
All of the switch LEDs will execute a chase pattern as program mode exits

### Programming Notes

1. Switches cannot be associated with the Master Switch and be programmed as a Momentary output at the same time. The Master Switch overrides any Momentary programming.
2. The last program command will override any previously programmed command for any given switch.  
IE. If switch 4 is associated with the Master Switch then programmed as a momentary switch, it will no longer be associated with the Master Switch

## Momentary Switch Programming Mode

- ▶ All Switches are factory set at Latching (Press ON / Press OFF)
- ▶ Switches 2 - 5 (4 switches total) can be set as momentary (ON only when switch is held)
- ▶ Switch 6 can be set as a 8-second timed momentary output  
(Press ON - Active for 8-seconds / Auto OFF)

### To Enter Momentary Switch Program Mode:

1. Press and hold switches 5 and 6 for 5-seconds (**S5 & S6** pictured above).  
All switch back light LEDs will blink ON and OFF twice  
This indicates that panel is in Momentary Switch Program Mode.
2. Press each switch that you want to program as momentary one (1) time. (**S2 - S5** above)  
All switches selected as momentary will flash while in Momentary Program Mode
3. Press switch a second (2nd) time to return it to Latching mode  
Switch will stop flashing
4. To exit Momentary Switch Program Mode, press Switch 1 a second (2nd) time  
All of the switch LEDs will execute a chase pattern as program mode exits

### To Program Switch 6 as Timed Momentary (can be performed at same time as steps above):

1. Repeat Step 1 above
2. Press and hold Switch 6 for as long as you want the timer to run during operation  
(Between 1-second & 8-seconds)
3. Repeat Step 3 above