

BROOKING INDUSTRIES, INC.

10132 NW 53rd St.
Sunrise, FL 33351

P 888-439-1925 or 954-572-0510
F 877-363-7301 or 954-578-6007



BR-993 Smart Switch Panel

Thank you for purchasing this Brooking Industries product. With proper installation and care, this unit will provide years of trouble-free service.

Function Table				
Wire	AWG	Color	Item	Function
1	20	Green	Switch 1	
2	20	Yellow	Switch 2	
3	20	Orange	Switch 3	
4	20	Brown	Switch 4	
5	20	Gray	Switch 5	
6	20	Violet	Switch 6	
7	20	Black	Ground	Ground
8	20	Tan	Ignition	Ignition
9	20	Blue	Gun Lock	Gun Lock
10	14	Red	Power	Power

Function column intentionally left blank. Please fill in appropriate functions and store in glove box for future reference / tech support.

BR-993 Smart Panel Wiring Instructions

Operation Notes

1. Install RED (J4-1) Power wire. Protect the circuit with a 15 Amp fuse (not supplied).
2. Install BLACK (J3-3) to Chassis Ground wire.
3. Install TAN (J3-2) to an ignition +12v circuit, 100mA input..
4. Install all of the outputs 1 through 6 to the various light bar outputs and other lights. (2 amps each output)
5. Install blue wire to Gun Lock output (+12v signal)
6. Test installation of each light by pressing corresponding switch on Smart Panel.

1. If a switch has been associated with the Pursuit switch, it can always be operated normally by pushing one (1) time to turn ON and a second (2nd) time to turn OFF.
2. If a switch has been associated with and turned on via the Pursuit switch it can be turned OFF by pushing it one (1) time.
3. If no buttons are pressed for one (1) minute while in programming mode, the unit will save the current settings and exit programming mode automatically.

Warning: In standard format, each switch is ONLY rated for a maximum 2 Amp per switch! Should your amp draw requirements exceed 2 Amps per switch, call 888-439-1925 to order our optional in-line 40 Amp relay kit, part number **BR-9RK**. These kits are available for \$12.95 each and will increase the maximum amp load capacity of one switch/lead to 40 Amps.

Scrape away any paint from the selected bolt hole and use a star washer and ring terminal to ensure a good, secure electrical connection to the chassis. The chassis ground must not be an insulated point.

Note: When drilling into any vehicle structure, ensure that both sides of the surface are clear of anything that can be damaged.

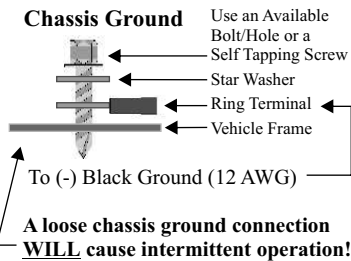

2A FUSE

Panel Back Inside View

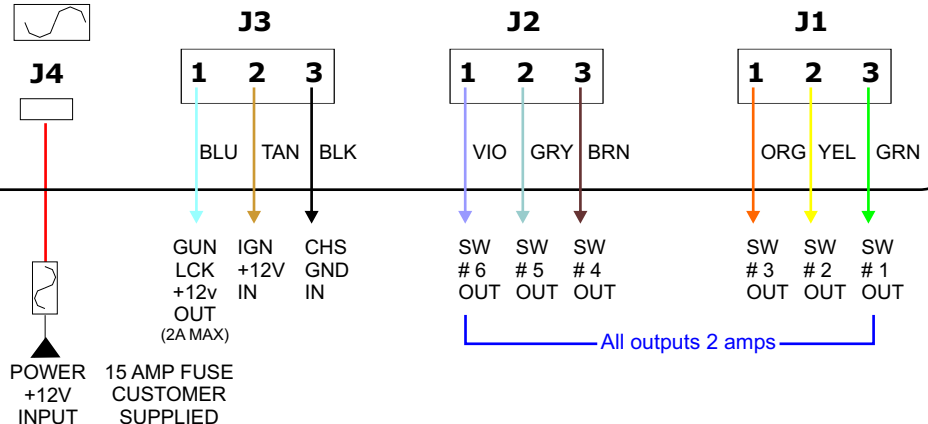

Auto - Walk - About Test

Enter Auto-Walk-About mode by holding down switches 1 & 6 at the same time for 5 seconds.

This test automatically turns each output (1 - 6) ON and OFF at a 5-second interval. The test runs for 120-seconds and can be exited at anytime by pressing any pursuit switch. The test can be re-set by pressing any switch 1 - 6.

Panel Front View

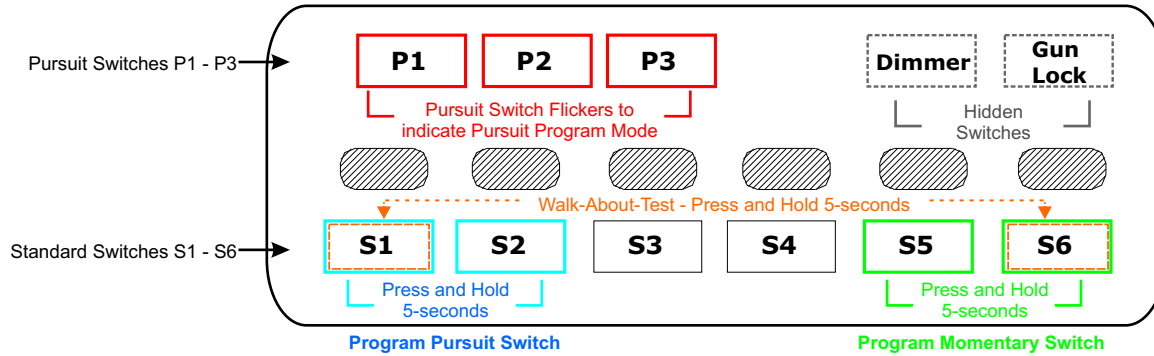

BR993 Operation

- Press any switch one (1) time to turn it On and press again to turn it OFF.
- Press any Pursuit switch (See Program Pursuit Switches Section)
Switch back light turns ON and all associated standard switches (S1 - S6) turn ON.
- Press gunlock switch
A momentary +12v signal is present at the gunlock output as long as button is pressed.
- Dimmer Switch (Bright, Medium, Low & Off)
The brightness level can be changed (whenever no Pursuit Switches are active) by pressing dimmer switch to sequence through the levels. Brightness level will remain until panel is powered OFF and will return to default when powered back ON.
To save the chosen brightness level as the default, select desired brightness level then press and hold dimmer switch for 5-seconds. Display will flash ON and Off three times to indicate that the setting has been saved as the default.
Note: If the brightness level is set to OFF, the brightness will automatically be adjusted to LOW when any switches are ON.

Circuit Protection

Each standard switch output is protected by an electronic smart switch (2 amp). Any time an over voltage or over temperature condition occurs, the output shuts OFF until condition is corrected. Once problem is corrected, function will automatically turn back ON.

- Notes:**
- There is no status indicator for an over voltage or over temperature condition.
 - The power wire must be fused near battery at 15 Amps
 - The logic circuit is internally protected by a 2 Amp fuse

Program Momentary Switch Options

All switches can be set as momentary, additionally Switch 6 can be set as a timed output of 1 to 25 seconds.

Special Note: Programming a Standard switch as momentary cancels any Pursuit switch association that may exist with that Standard switch.

To Enter Momentary Program Mode:

- Press and hold switches S5 and S6 for 5-seconds.
All back lights will blink ON and OFF twice
Pursuit switch P3 will start to flicker indicating panel is in Momentary Program Mode
- Press each switch that you want to program as momentary one (1) time.
Switches programmed as momentary will flicker
- To exit Momentary Program mode, press Pursuit switch P3 a second (2nd) time
Note: All of the switch buttons will illuminate with a chase pattern to indicate the start of normal operation.
If no button is pressed for 60-seconds, the panel will exit program mode automatically.

To Program Switch 6 as Timed Momentary

- Repeat Step 1 above
- Press and hold Switch 6 for as long as you want the timer to run during operation. (Switch will flash for the timed number of seconds programmed)
- Repeat Step 3 above

Program Pursuit Switches

All of the Standard switches S1 through S6 can be associated with any of the Pursuit switches. Thus, when in normal operation, any combination of switches S1 - S6 can be activated just by pressing a Pursuit switch. Each Pursuit switch can be programmed with a different combination of S1 - S6.

Special Note: Programming a Standard switch as momentary cancels any Pursuit switch association that may exist with that switch.

To Enter Program Mode:

- Press and hold switches S1 and S2 for 5-seconds.
All back lights will blink OFF then ON twice
Pursuit switch P1 will start to flicker indicating panel is in Pursuit Program Mode
- Press each switch S1 - S6 you want associated with Pursuit Switch P1
Selected switch will flicker, indicating it has been associated with the Pursuit switch
*Any number and combination of Standard switches may be associated with each Pursuit switch
- Press Pursuit switch P2 and repeat step 2 (Pursuit switch P2 will flicker)
- Press Pursuit switch P3 and repeat step 2 (Pursuit switch P3 will flicker)
- To exit Pursuit program mode, press the Pursuit switch that is flickering a second (2nd) time
Note: All of the switch buttons will illuminate with a chase pattern to indicate the start of normal operation.
If no button is pressed for 60-seconds, the panel will exit program mode automatically.