

# BROOKING INDUSTRIES, INC.

10132 NW 53rd St.  
Sunrise, FL 33351

P 888-439-1925 or 954-572-0510  
F 877-363-7301 or 954-578-6007

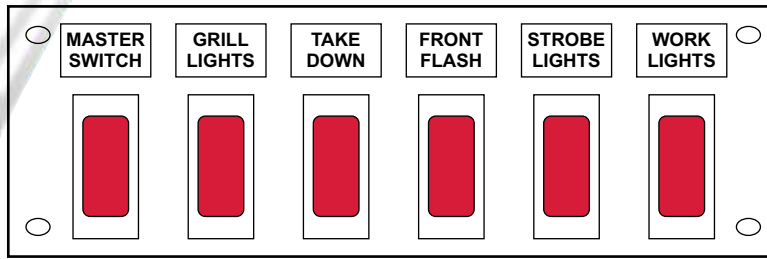

## SP-6SW 6 Function Switch Plate

Thank you for purchasing this Brooking Industries product. With proper installation and care, this unit will provide years of trouble-free service.

### SP-6SW 6 Function Switch Plate

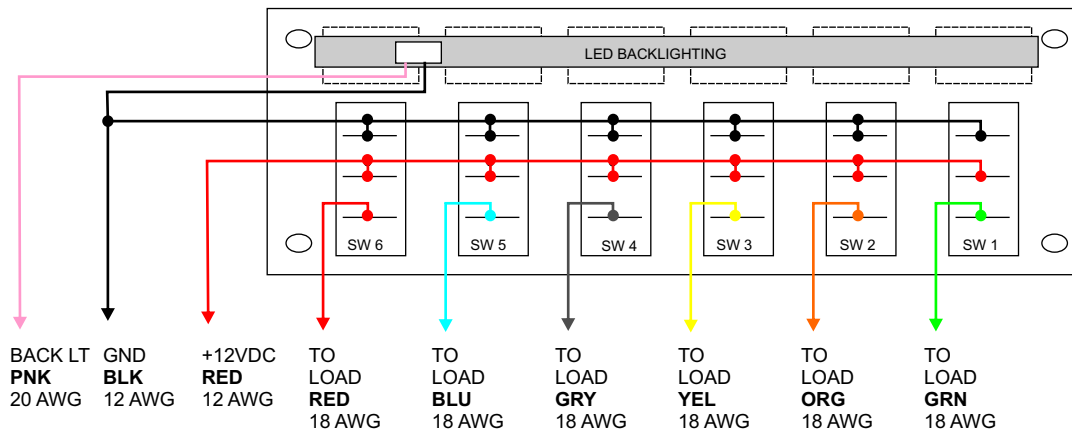

LED Backlighting for  
Legends / Titles

6 Red Lighted  
Rocker Switches  
Rated @ 15 Amps Each

Wire	AWG	Color	Item	Function
1	18	Green	Switch 1	
2	18	Orange	Switch 2	
3	18	Yellow	Switch 3	
4	18	Grey	Switch 4	
5	18	Blue	Switch 5	
6	18	Red	Switch 6	
7	12	Red	Power	Power
8	12	Black	Ground	Ground
9	20	Pink	Back Lt	Back Lt

Function column intentionally left blank. Please fill in appropriate functions and store in glove box for future reference / tech support.

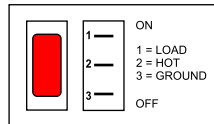

Scrape away any paint from the selected bolt hole and use a star washer and ring terminal to ensure a good, secure electrical connection to the chassis. The chassis ground must not be an insulated point.

**Note:** When drilling into any vehicle structure, ensure that both sides of the surface are clear of anything that can be damaged.

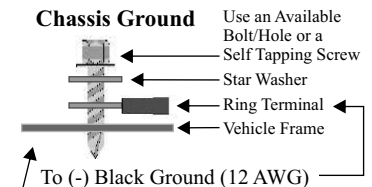

**A loose chassis ground connection WILL cause intermittent operation!**

#### Mounting:

The SP-6SW has been designed to fit Havis® and Jotto Desk® consoles.

#### Wiring:

Before making any electrical connections, determine the polarity of the vehicle's electrical system ground. Most vehicles require the RED (+) positive wire (12 AWG) be connected to the power source and the BLACK (-) negative wire (12 AWG) to be connected as the chassis ground wire. After making all the connections, verify that there are no short circuits to ground prior to connecting the positive (+) RED wire to the power source. The BLACK ground wire should be connected to the vehicle chassis as close to the unit as possible.

Connect the appropriate warning light accessory to the color coded wire which corresponds to the switch you want to use to control the accessory.

#### Precautions:

Do not connect this system to the positive terminal of the battery until installation is complete and you have verified there are no short circuits to the ground.